

# ***MANUAL ENGLISH***

<b>1.</b>	<b>GENERAL</b>	<b>1</b>
1.1	Welcome	1
1.2	Use of the manual	1
1.3	Service and technical support	1
<b>2</b>	<b>SAFETY</b>	<b>2</b>
2.1	EnergyPak battery & charger	2
2.2	Luggage carrier	2
2.3	Bike usage	2
2.4	Transportation	2
<b>3</b>	<b>OVERVIEW E-PARTS</b>	<b>3</b>
3.1	Explanation	3
3.2	EnergyPak & Charger	4
3.2.1	<i>Overview</i>	4
3.2.2	<i>General remarks</i>	5
3.2.3	<i>New EnergyPak</i>	5
3.2.4	<i>Charging</i>	6
3.2.5	<i>Usage</i>	10
3.2.6	<i>Storage</i>	11
3.4	RideControl	12
3.3	SyncDrive	12
3.4.2	<i>Settings</i>	14
3.4.3	<i>Reset settings</i>	17
3.4.4	<i>Switch (Km/h&lt;-&gt;Mph)</i>	17
3.4.5	<i>Position adjustment</i>	18
<b>4</b>	<b>BIKE USAGE</b>	<b>19</b>
4.1	Maintenance	19
4.2	Range	19
4.3	Shifting recommendations	19
4.4	keys	19
<b>5</b>	<b>TROUBLESHOOTING</b>	<b>20</b>
5.1	Error indication	20
5.2	EVO display	20
5.3	Charge display	20
5.4	RideControl ONE	21
<b>6</b>	<b>FREQUENTLY ASKED QUESTIONS</b>	<b>22</b>
6.1	Ridecontrol - display	22
6.2	EnergyPak	22
6.3	SyncDrive motor	23
6.4	Miscellaneous	23
<b>7</b>	<b>LEGAL DOCUMENTATION</b>	<b>24</b>
7.1	Warranty	24
7.2	Exclusions	25
7.3	Conformity	25
7.4	FCC	25
7.5	IC	26

# 1. GENERAL

## 1.1 WELCOME

Welcome and congratulations on your purchase of a new Giant E-bike, the fun of pedalling is only moments away.

### Ride Life, Ride Giant

Nothing makes us happier than seeing people out riding bikes. Since 1972 Giant has manufactured quality bikes for every type of terrain and rider imaginable. Giant bicycles have allowed millions of cyclists just like you the opportunity to live happier, healthier lives because of the joy, exercise and sheer exhilaration that riding a bicycle brings. And it is this commitment to sharing the joy of the ride that inspires us to continually offer the world's most innovative bicycles.

## 1.2 USE OF THE MANUAL

Read this manual carefully before you start riding on your new Giant E-bike. Safety instructions are very important and should not be overlooked. By doing so you will have a better understanding of the general operation of the various bike parts. Some frequently asked questions will be covered as well. Obviously, legal documentation is included in this manual at your service. So, take a moment to read this manual before you start riding.

## 1.3 SERVICE AND TECHNICAL SUPPORT



This manual is not intended to be an extensive reference book about service, maintenance and/or repairs. Please consult your dealer for service and technical support. You can find more information about our products or find a dealer via our global website([www.giant-bicycles.com/](http://www.giant-bicycles.com/)).



## 2 SAFETY

### 2.1 ENERGYPAK BATTERY & CHARGER



- Keep the EnergyPak battery & charger away from water and open fire.
- Do not use the battery & charger for other purposes.
- Do not connect positive and negative terminals;
- Keep the battery away from children and pets.
- Do not subject the battery & charger to shocks (e.g. by dropping).
- Do not cover the battery & charger or place objects on top of it.
- Stop the charging procedure immediately if you notice a strange smell or smoke.
- In the unlikely case that the battery is on fire, do NOT try to put it out with water. Use sand instead and call emergency services immediately.

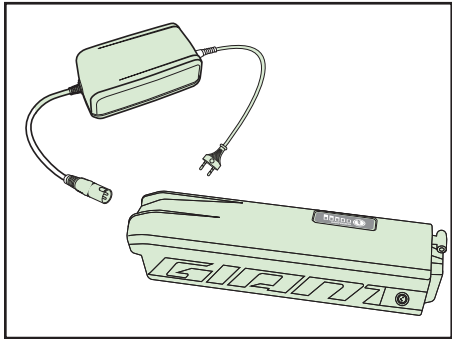

Avoid contact with battery and charger during charging operation. The charger heats up. Please read/note additional information on the rear of the battery case.

### 2.2 LUGGAGE CARRIER

Some type of bikes have the battery holder and luggage carrier combined. Please ensure that luggage is securely fixed to avoid that it can cause damage to the battery and/or holder.

Maximum rear carrier load including EnergyPak:  
22 kG.

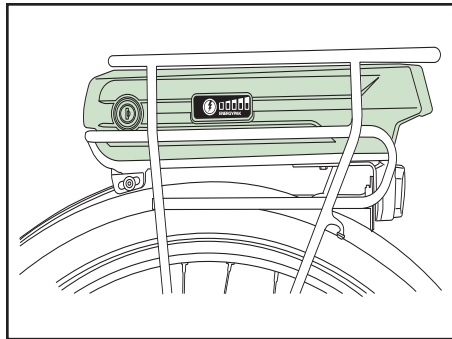

### 2.3 BIKE USAGE

Before using the E-bike on the open road, ride the bike in a secure area to get acquainted with riding a bike with electric pedalling support. Try all settings on the bike and get familiar with the results.

### 2.4 TRANSPORTATION



Batteries are not designed to be on the bike during transportation by car. Batteries must be taken off the bike(s) and transported inside the car.



## 3 OVERVIEW E-PARTS

### 3.1 EXPLANATION

Giant E-bikes are equipped with parts that work together to make a smooth and powerful assisted E-bike.

#### **ENERGYPAK**

Giant's integrated Lithium-ion battery packs are unique because they have the highest energy density in the market. If we consider weight and size, Giant EnergyPaks produce the best performance in an integrated package. Furthermore, this EnergyPak charges twice as fast compared to earlier battery systems and provides a superb maximum range. The batteries are thoroughly tested in Giant factories to ensure reliability. Giant E-bikes are equipped with 300Wh, 400Wh or 500Wh EnergyPaks.

#### **SYNCDRIVE** Powered by YAMAHA

Innovation, manufacturing expertise and a motor system powered by Yamaha all combine to help extend any rider's abilities. The new SyncDrive motor delivers smooth pedaling power that's sonically tuned for quiet performance. The SyncDrive motor is widely acclaimed for its performance and reliability. The small mid-drive motor delivers a massive maximum 80Nm (Newton Meters) of torque, and gives you the option of using a double chainring crankset so you can choose an easier gear, which requires less energy from the rider and battery.

#### **RIDECONTROL**

The handlebar-mounted command center provides easy-to-operate controls with a more ergonomic button that controls the display and support levels in a comfortable way. The RideControl display has a central position and is multi-adjustable. It provides riders with the following important information:

- Battery level indicator
- Support level indicator
- General indicators like speed, distance etc.

The lowest power assist level can be used for riding urban and suburban roads when minimal assistance is needed. Eco level requires less battery capacity and helps you cover a greater distances. The highest level gives you the highest power boost to climb steep hills. It's the perfect choice when you're riding the most challenging mountains and terrain.

## 3.2 ENERGYPAK & CHARGER

### 3.2.1 Overview

#### EnergyPak (top release)

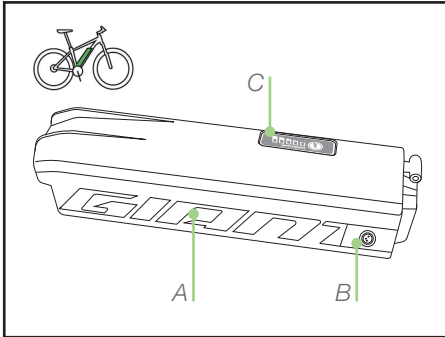

- A EnergyPak
- B Charging socket
- C Energy Level check (button)

#### EnergyPak (side release)

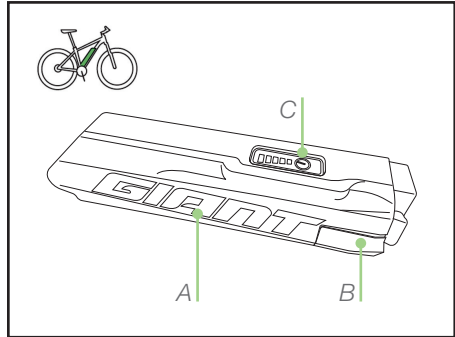

- A EnergyPak
- B Charging socket
- C Energy Level check (button)

#### EnergyPak (integrated)

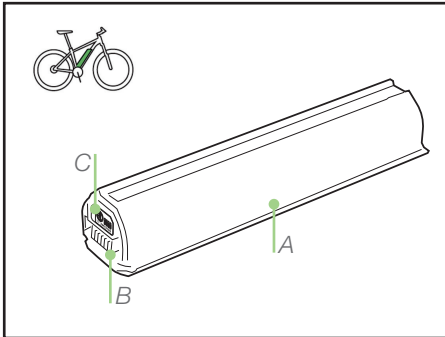

- A EnergyPak
- B Charging socket
- C Energy Level check (button)

#### EnergyPak (rear rack)

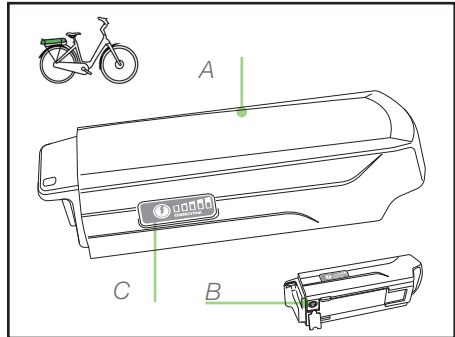

- A EnergyPak
- B Charging socket
- C Energy Level check (button)

### 4A charger

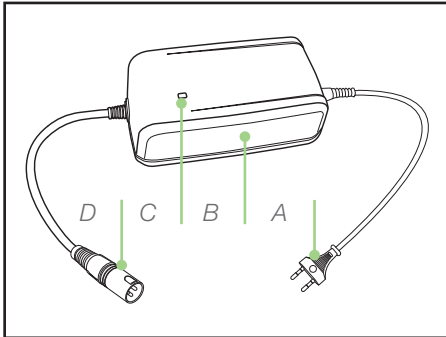

- A AC socket (110~230V) (type will vary)
- B Charger
- C Charging indicator
- D Charging socket

### Smart charger

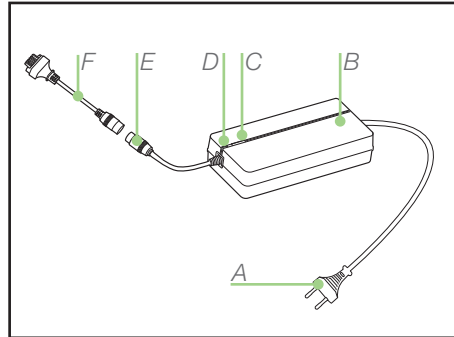

- A AC socket (110~240V) (type will vary)
- B Charger
- C Charging indicator 60%
- D Charging indicator 100%
- E Charging socket
- F Charge adapter



### 3.2.2 General remarks

- Stop the charging procedure immediately if you notice a strange smell or smoke. Take the EnergyPak to an Authorised Giant Dealer for service or replacement.
- In the unlikely case that the EnergyPak is on fire, do NOT try to put it out with water. Use sand instead to cover the fire and call emergency services as soon as possible.

### 3.2.3 New EnergyPak

A new EnergyPak is shipped in a protective 'hibernate' state. Such an EnergyPak needs to be activated before it can be used;

- A 'hibernate' EnergyPak can be recognized by pushing the energy level check button. The LED's of the EnergyPak will not light up.
- Plug an active charger in the EnergyPak.
- Unplug the charger from the EnergyPak.
- The EnergyPak is now out of 'hibernate' state. Pushing the energy level check button will result in lighting up LED's.
- The EnergyPak is ready for usage.

It is not possible for an EnergyPak to go back to 'hibernate' state once it is awoken. Usually, the dealer will charge the EnergyPak and therefore undo 'hibernate' state.



### 3.2.4 Charging

- Charging the EnergyPak battery should be at room temperature ( $\pm 20^{\circ}\text{C}/68^{\circ}\text{F}$ ). Charging below  $0^{\circ}\text{C}$  or above  $40^{\circ}\text{C}$  ( $32^{\circ}\text{F}\sim 104^{\circ}\text{F}$ ) can lead to insufficient charging and can be harmful to the battery life cycle.

#### 4A charger

- Not connected:  
Charger LED is green (constant).
- During charging:  
Charger LED is red (constant)
- Charging issue:  
Charger LED is red (blinking)
- Charging is completed (100%):  
Charger LED is green (constant)

#### Smart charger

- Not connected:  
Charger LED1 is green (constant).
- During charging (100%):  
Charger LED1 is red (constant)
- Charging is completed (100%):  
Charger LED1 is green (constant)
- Charging issue:  
Charger LED1 is red (blinking)

#### Long term storage charge (60%)

- Connect charger
  - Press LED2 button
  - Charging will be done like regular charging procedure, except:  
LED2 will be yellow (constant)
- Charging will stop at 60% (for long time storage)





## Charging inside the bike

### EnergyPak (integrated)

1. Connect the charger to the charge port on the bike
2. Connect the charger to an AC outlet.
3. Charging operation can be discontinued at any given time.
4. Disconnect the charger first from the outlet and then from the EnergyPak.
5. The bike is ready for usage.

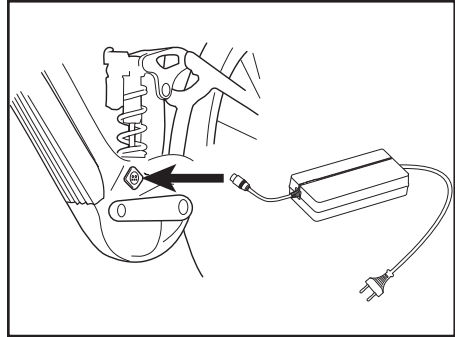

### EnergyPak (side release, top release)

1. Connect the charger to the EnergyPak. Connect the charger to an AC outlet.
2. Charging operation can be discontinued at any given time.
3. Disconnect the charger first from the outlet and then from the EnergyPak.
4. The bike is ready for usage.

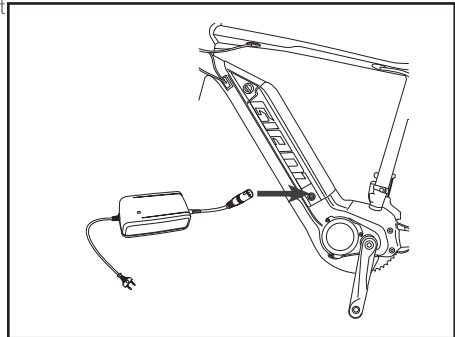

### EnergyPak (rear rack)

1. Connect the charger to the EnergyPak outlet on the front of the rear rack.
2. Connect the charger to an AC outlet.
3. Charging operation can be discontinued at any given time.
4. Disconnect the charger first from the outlet and then from the EnergyPak
5. The bike is ready for usage.

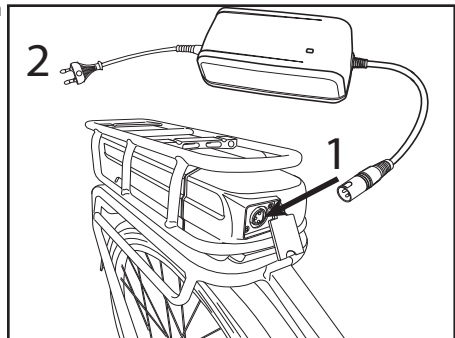

## Charging outside the bike

### EnergyPak (integrated)

1. Insert the key and unlock the EnergyPak.
2. For top loading integrated batteries only: Lift out the EnergyPak and continue with step 6.
3. Support the weight of the battery.
4. Push the anti-drop protection lever to fully unlock the EnergyPak.
5. Lower and pull the battery out of the bike.
6. Connect the charge adapter (B) to charger.
7. Connect the charger to the EnergyPak. It only fits in one orientation.
8. Connect the charger to an AC outlet.
9. Charging operation can be discontinued at any given time.
10. Disconnect the charger first from the outlet and then from the EnergyPak
11. Reinstall the EnergyPak and make sure the slots are aligned correctly at the bottom
12. Push the top of the EnergyPak and make sure the EnergyPak is secured properly. A 'click' can be noticed while doing so.
13. Pull out the key.
14. The bike is ready for usage.

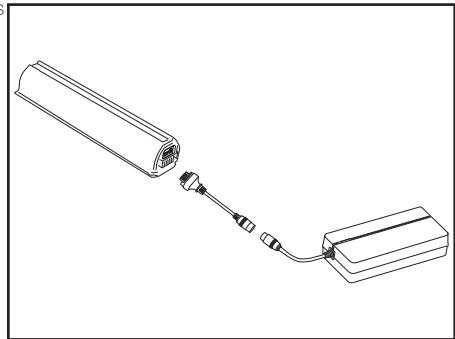
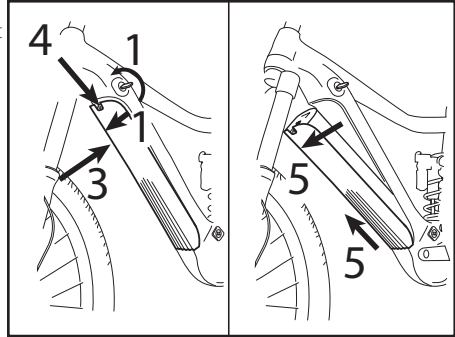

### EnergyPak (side release)

1. Insert the key and unlock the EnergyPak.
2. Slide the top of the EnergyPak battery sideways to the left.
3. Lift out the EnergyPak.
4. Connect the charger to the EnergyPak.
5. Connect the charger to an AC outlet.
6. Charging operation can be discontinued at any given time.
7. Disconnect the charger first from the outlet and then from the EnergyPak.

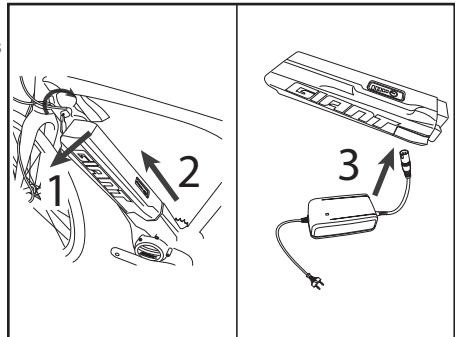

8. Reinstall the EnergyPak and make sure the slots are aligned correctly at the bottom.
9. Push the top of the EnergyPak and make sure the EnergyPak is secured properly. A 'click' can be noticed while doing so.
10. Pull out the key.
11. The bike is ready for usage.

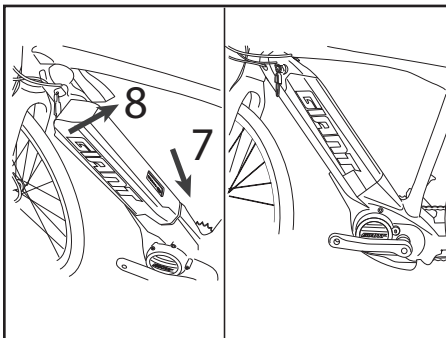

### EnergyPak (top release)

1. Insert the key and unlock the EnergyPak, pull the EnergyPak battery backwards at the top.
2. Lift out the EnergyPak.
3. Connect the charger to the EnergyPak.
4. Connect the charger to an AC outlet.
5. Charging operation can be discontinued at any given time.
6. Disconnect the charger first from the outlet and then from the EnergyPak.

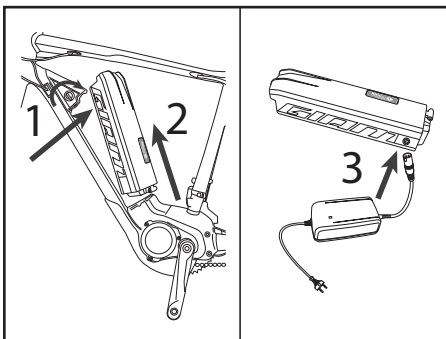

7. Reinstall the EnergyPak and make sure the slots are aligned correctly at the bottom.
8. Push the top of the EnergyPak and make sure the EnergyPak is secured properly. A 'click' can be noticed while doing so.
9. Pull out the key.
10. The bike is ready for usage.

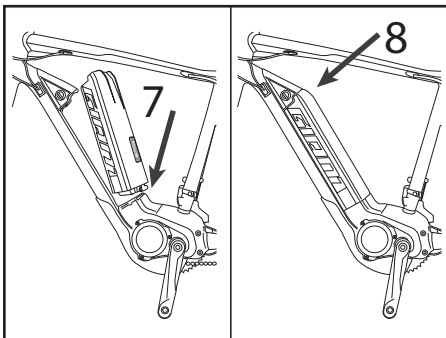

### EnergyPak (rear rack)

1. Insert the key and unlock the EnergyPak, hold the grip and pull the EnergyPak backwards.
2. Slide out the EnergyPak.
3. Connect the charger to the EnergyPak.
4. Connect the charger to an AC outlet.
5. Charging operation can be discontinued at any given time.
6. Disconnect the charger first from the outlet and then from the EnergyPak.
7. Reinstall the EnergyPak and make sure the slots are aligned correctly in the bottom.
8. Push the EnergyPak forwards and make sure the EnergyPak is secured properly. A 'click' can be noticed.
9. Pull out the key.
10. The bike is ready for usage.

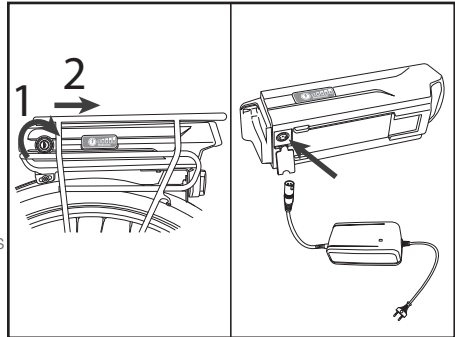

### 3.2.5 Usage

If only 3% of the EnergyPak power is left, the EnergyPak will automatically switch assistance to ECO mode in order to save energy.

If only 1% of the EnergyPak power is left, assistance will automatically stop. Power assist level indication bar will blink 3 times. Lights can still be used for approximately 2 hours.

Power in the EnergyPak can be checked by pushing the Energy Level check button.

Discharge the EnergyPak completely by riding the bicycle after 15 normal charges or at least every 3 months totally before charging the EnergyPak again. This will increase the lifespan of the EnergyPak.

When an EnergyPak is connected to the bike, some power will get lost in the system when the bike is not in use. To prevent this, EnergyPak can be disconnected from the bike when not in use for more than a few days.

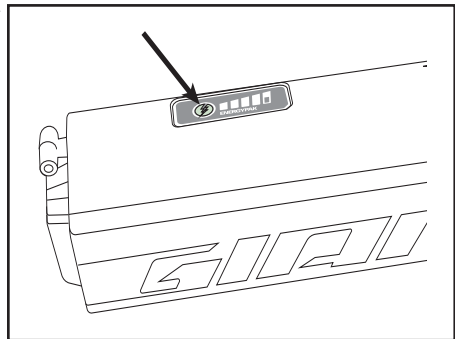

**4A charger time table (200V-240V)**

	Charge time in hours		
	300Wh 8,8Ah	400Wh 11,3Ah	500Wh 13,8Ah
<i>80% charge</i>	1:45h	2:00h	2:45h
<i>100% charge</i>	3:30h	4:30h	5:00h

**4A charger time table (110V)**

	Charge time in hours		
	300Wh 8,8Ah	400Wh 11,3Ah	500Wh 13,8Ah
<i>80% charge</i>	2:20 h	3:00 h	3:40 h
<i>100% charge</i>	4:40 h	6:00 h	7:20 h

**Smart charger time table (110-240V)**

	Charge time in hours		
		400Wh 11,6Ah	500Wh 13,8Ah
<i>60% charge</i>		1:00 h	1:30 h
<i>80% charge</i>		1:50 h	2:20 h
<i>100% charge</i>		3:00 h	3:40 h

**3.2.6 Storage**

If the bike is not used for a longer period (one month or more) the EnergyPak is best stored:

- At 60% of its capacity. For 'smart charger', that is a functionality.
- Separate from the bike.
- At temperatures between 0°C and 40°C.
- Checked every month to see if at least one LED is still blinking. Charge when needed.

Charging the EnergyPak should be done at a minimum of every 3 months. Negligence to this could void the warranty of the EnergyPak.

### 3.3 SYNCDRIVE

The SyncDrive motor is responsible for the pedalling assistance of your E-bike. Information from internal sensors and the speed sensor are being processed to give a smooth and natural ride. Sideways play of the bottom bracket axle of one millimeter maximum is designed in the motor for best endurance.

#### SyncDrive Central

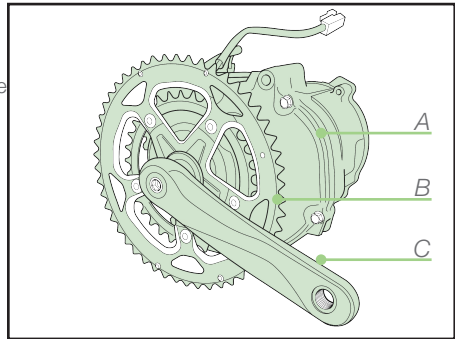

- A Motor
- B Chainwheel
- C Crank

### 3.4 RIDECONTROL

#### 3.4.1 Overview

##### Remote Controller

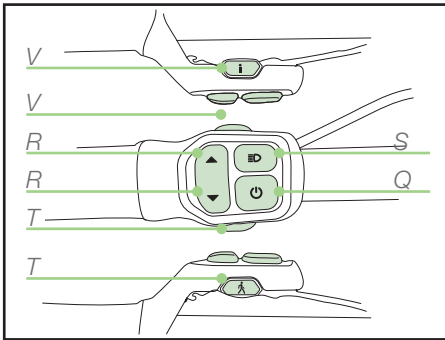

- Q On/off
- R Assistance level (up/down)
- S Lights
- T Walk assist
- V General indication

##### RideControl ONE

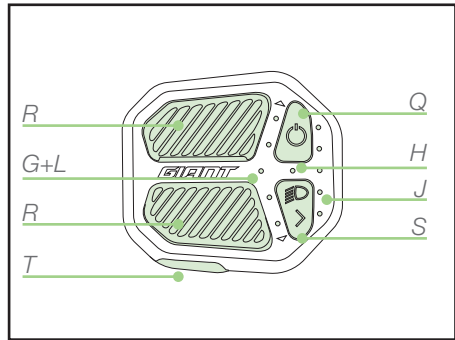

- Q On/off
- R Assistance level (up/down)
- S Lights & General indication
- T Walk assist
- G Power assist indicator (5 LEDs)
- H Lighting indicator
- J EnergyPak charge indicator (5 LEDs)
- L Error code indicator



## Displays

### EVO display (5 assist modes)

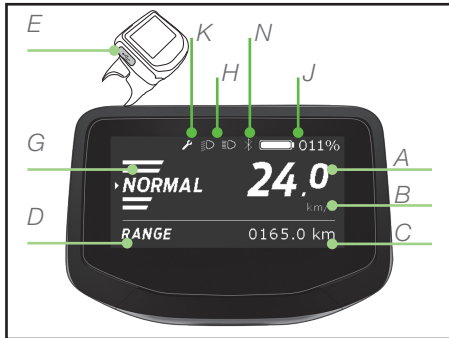

### Charge display (5 assist modes)

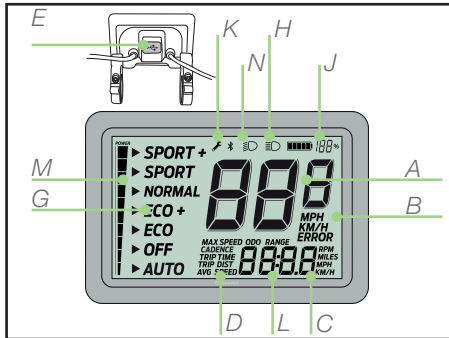

### EVO display (3 assist modes)

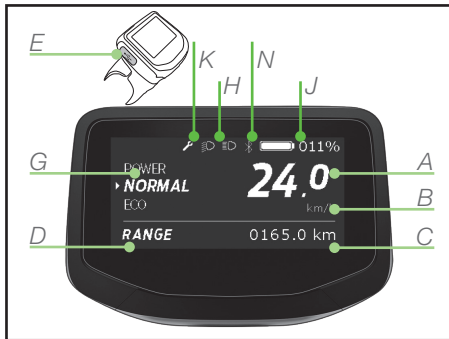

### Charge display (3 assist modes)

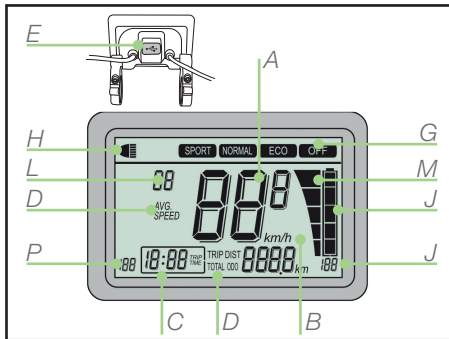

A Speed

B Units (Km/h or mph)

C Indications

D Indication settings:

Max speed, Average speed, remaining range, ODO (total distance), Trip distance, Trip time, Cadence.

E Micro USB outlet (Output 5V–0,5A)

G Power assist indication

H Lighting indicator (high beam)

J EnergyPak charge indicator

K Service indicator

L Error code indicator

M Torque indicator

N Bluetooth connection

P Remaining range

\* Display may vary from shown. Not all functions are available for all displays.



### 3.4.2 Settings

#### On:

Press the ON/OFF button (Q) to switch on the system;

#### Off:

Press the ON/OFF button (Q) for at least three seconds and release the button to switch off the system;

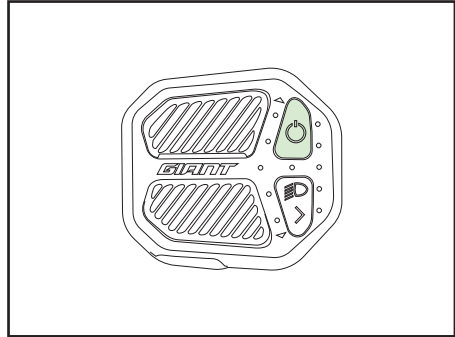
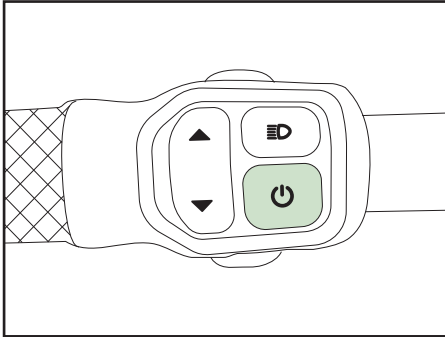

#### Power assist:

Press the Assistance level button (R) up or down to choose the correct Power assist level (G).

- The lower the assistance, the higher the range.
- The higher the assistance, the lower the range.
- OFF: For riding without power assist but with bicycle computer and light functions.
- AUTO: (Some) Ride Life motors have 'auto' assist mode.

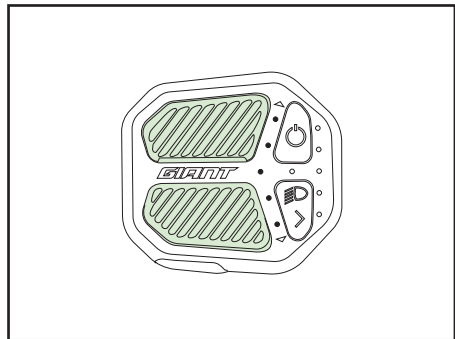
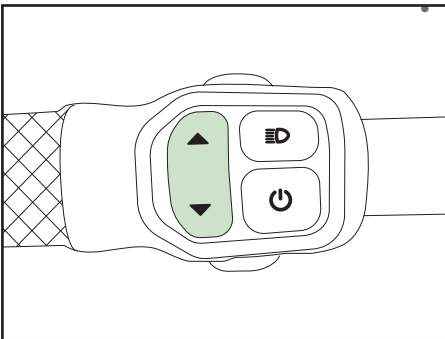

#### Power assist 'AUTO':

The motor automatically detects the amount of support the rider needs. The combination of the Pedal-Plus 6-sensor technology and the instantaneous response of the SyncDrive Life motor creates a smooth and powerful riding experience. It maximizes energy efficiency for both the rider and the battery system, optimizing power depending on the slope and saving power on flats and descents.

The sequence in assist levels for these bike is: AUTO, OFF, ECO, ECO+, NORMAL, SPORT, SPORT+.

'AUTO' assist level is indicated on Charge and EVO displays via power assist indication (G). On RideControl ONE, only the middle power assist indication LED is constantly engaged.





### Walk assist:

Walk assist is used to help you while walking with the bike. It works up to a speed of 6km/h / 4mph. Walk assist is at its most powerful in the lowest gear, which means the smallest chain wheel up front and the biggest sprocket on the rear.

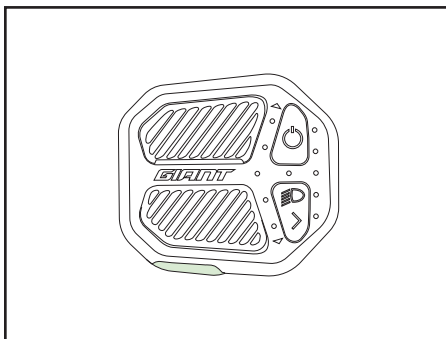
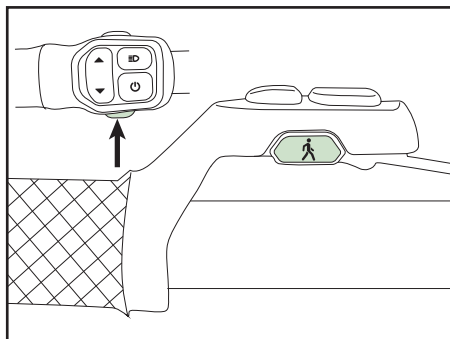

### Lighting

Press the Light button (S) to switch the lights on/off. The EnergyPak supplies power to the lights. The lights will stay on when the bicycle is standing still. For S-pedalecs (high speed E-bikes) this button switches between low beam and high beam.

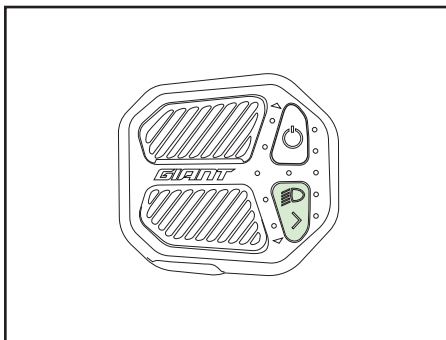
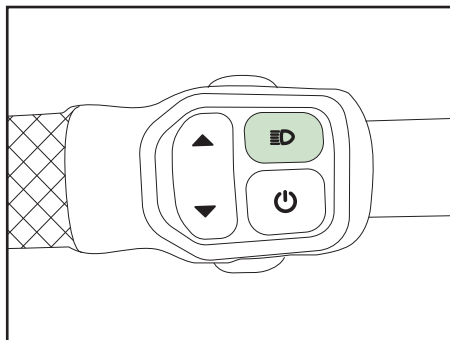

For **EVO** display:

- When the bike is switched on, lights will be switched on. Backlight is on as well.
- Press button to dim backlight. Lights are still on.
- Press button again to switch off light and backlight.

- For **CHARGE** display:

- When the bike is switched on, the display shows its initial settings without backlight.
- When lights are switched on, the backlight will be switched on for better visibility in darkness.

### Integrated **head tube light**:

Some bikes (Prime-E+) have additional daylight integrated in head tube. Lighting system for these bikes is slightly different.

- Under the fender front light there is a switch (A). This switches between 'auto' and 'manual' lighting.
- When the switch is in 'auto' mode, the light sensor (B) on top of the fender front light (C) switches between head tube light (D) or front fender light (C) depending on the amount of ambient daylight. The system requires 5 seconds to adapt from head tube light to fender light, 20 seconds the other way around.
- When the switch is in 'manual' mode, the light button on the handle bar will switch the front fender light only. The head tube light can't be used in this mode.



### **Battery indications**

Battery level is indicated via EnergyPak charge indicators (J). For Charge and EVO displays, this is visible via indicator bar and by digits. For RideControl ONE, battery level is indicated via LEDs on the right side of the button.

#### **For RideControl ONE only:**

- When battery power is less than 10%, bottom LED glows orange continuously.
- When battery power is less than 3%, or when the bike is in 'OFF' mode', bottom LED blinks orange. Assist will shut down, The light system is still functional.

#### **Charging RideControl ONE:**

- While charging, battery level LEDs will blink according charging level of the EnergyPak battery.
- When the EnergyPak battery is completely charged and connected to charger, all battery level LEDs are on.

## General indications

Press General indication button (V) to switch the following display indications:

- For **EVO** display:

- Trip time, distance, average speed, top speed, ODO (total distance), remaining range, cadence.

The display will startup in the position it was switched off.

In case the power assist mode is in 'OFF', the remaining range will show '999'.

- For **Charge** display:

- Speed <-> average speed
- Trip distance / ODO (total distance)

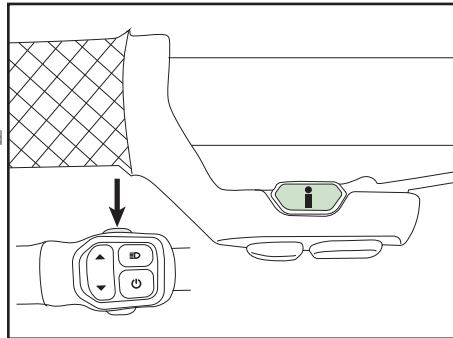

### 3.4.3 Reset settings

Press both Assistance buttons 'up' and 'down' (R) simultaneously for THREE seconds to reset trip distance, trip time and average speed. This reset can only be done when one of these settings is shown on the display.

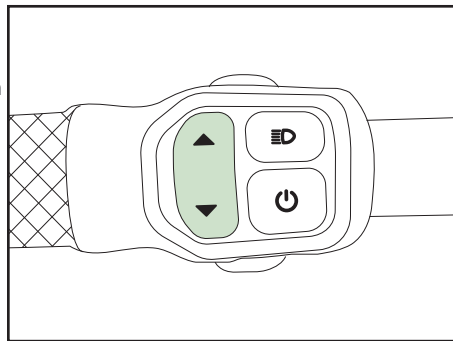

### 3.4.4 Switch (Km/h<->Mph)

Press the Settings button (V) for 5 seconds to switch between Km/h and Mph indication.

For EVO displays, Both kilometers and miles units will be displayed.

For Charge display, only 'km/h' and Km' is displayed'. Both units 'm' and 'mph' will not be displayed.

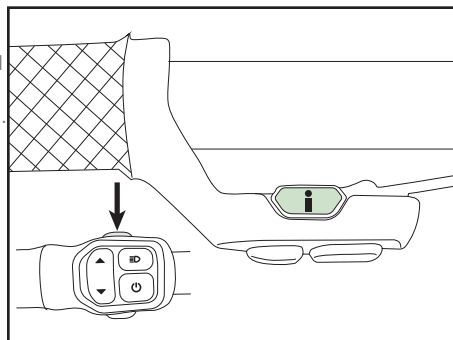

### 3.4.5 Position adjustment

- For **EVO** display:

Loosen bolts (D) crosswise.

Adjust the angle of the aluminium housing.

Tighten the bolts clockwise and crosswise. Do not overtighten.

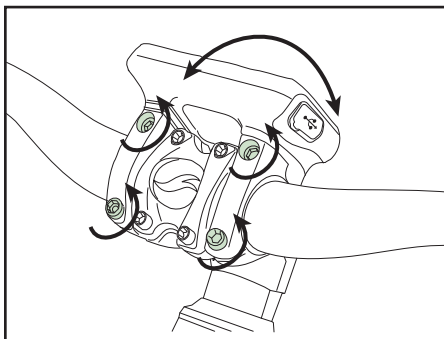

- For **CHARGE** display:

Loosen bolts (D). Adjust the angle of the LCD mount.

Tighten the bolts. Do not overtighten. Allowing the display to rotate a little will prevent substantial damage in case of a crash.

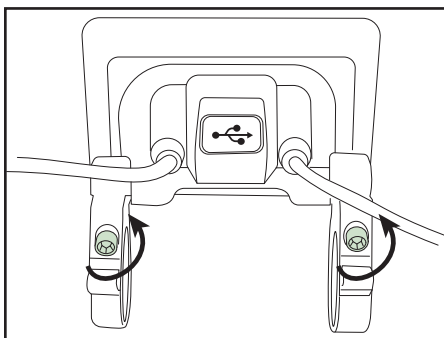

- For **Remote control**:

Unscrew the grip bolt a few turns counter clockwise.

Adjust the angle of the remote control.

Tighten the bolt.

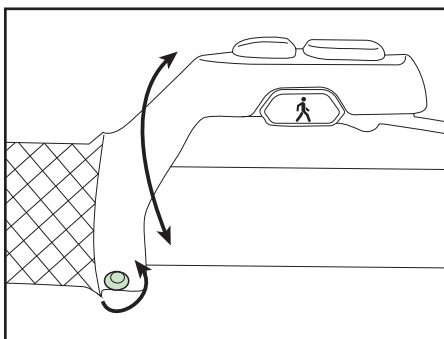

## 4 BIKE USAGE

### 4.1 MAINTENANCE

Giant Hybrid E-bikes use plastic shells to cover the electric parts, so it is forbidden to use excessive water to wash the plastic. Use a soft cloth with a neutral solution to wipe the dirt off the plastic shells. After that, wipe it dry with a clean soft cloth.

#### CAUTION

Do not use high-pressure water or air hoses for cleaning. It can force water into electric components, which may cause malfunctioning.

#### CAUTION

Do not wash plastic components with excessive water. When the internal electrical parts are infected with water, the insulator may corrode which leads to power-drain or other problems



Do not use soap solutions to wash the plastic components. Non-neutral solutions may cause color-change, distortion, scratching etcetera.

#### Avoid leaving the bike outdoors

When not riding, keep the bike in a location where it will be protected from snow, rain, sun etc. Snow and rain can cause the bike to corrode. The ultraviolet from the sun can fade the paint or crack any rubber or plastic on the bike.

### 4.2 RANGE

The range on one charge strongly depends on several circumstances, such as (but not only):

- Weather conditions such as ambient temperature and wind;
- Road conditions such as elevation and road surface;
- Bike conditions such as tire pressure and maintenance level;
- Bike usage such as acceleration and shifting;
- Rider and luggage weight;
- Charge and discharge cycles.

### 4.3 SHIFTING RECOMMENDATIONS

For better range, Giant advises to shift according to the speed. For low speeds and setting off, low gearing is best. The higher the speed, the higher the gear can be chosen. For smooth support and optimum range, it is best to release pedal pressure while shifting gears.

- High speed, high gear.
- Low speed, low gear.
- Release power during shifting.

### 4.4 KEYS

The bike comes standard with two keys that are used for the battery lock. Some bike come standard with a ring lock as well. For those bikes the keys fit both locks. A qualified locksmith can duplicate the keys. For bikes without bike lock, onboard charging can lead to the battery lock key being unused for a long period. This key is needed for maintenance and repair however. Be aware of this when storing the key.



- Keep non-used key(s) in a safe place for repairs and emergencies.
- Make sure to have always at least one spare key.
- Always bring the key when going to the dealer for maintenance or repairs.

# 5 TROUBLESHOOTING

## 5.1 ERROR INDICATION

An error notification will be shown on the display in case a problem is detected in the system. In the majority of cases there is no reason for immediate concern, however it is recommended to visit your Giant dealer to have it checked. For removing all error codes from display, visiting your Giant dealer is required.

## 5.2 EVO DISPLAY

In case of a system error the EVO display can show various error messages in following sequence;

1. 'system message' for 2 seconds.
2. One of these root causes:
  - 'SyncDrive error'
  - 'RideControl error'
  - 'Bluetooth error'
  - 'EnergyPak error'
  - 'Speed sensor error'
3. Only in case of 'SyncDrive error', 'no power support' will be shown and power assist will stop. (When EnergyPak is empty, power assistance will stop as well)
4. 'Your E-bike needs servicing'
5. Service indication pictogram shows in normal screen until dealer is visited for servicing.

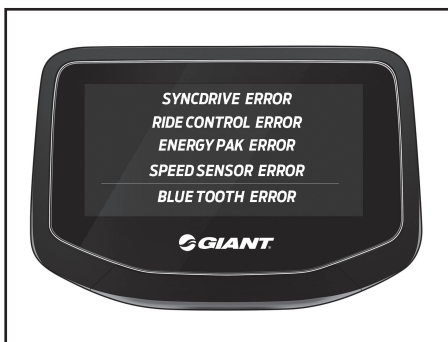

## 5.3 CHARGE DISPLAY

In case of an error, 'EnergyPak indicator' (J) and 'Error code indicator' (L) will blink 3 times. The root cause will be displayed by 'Error code indicator' (L). If error code 'A1' is indicated or when EnergyPak is empty, power assistance will stop. For all other error codes power assistance will continue.

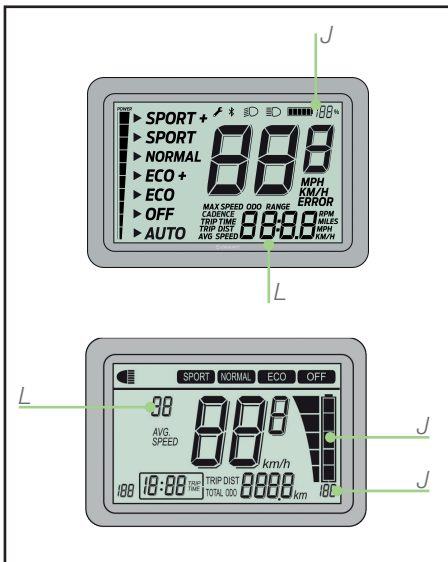

## 5.4 RIDECONTROLE ONE

In case of a system error, the RideControl ONE display can show various error messages. Lighting indicator (H) will flash, accompanied by one of the error code indicators (L) that double as power assist indicators). Switching off and on will reset the system in most cases. If so, continuing a bike ride is no problem. Contact a dealer for final test results via Service Tool.

Note: LEDs are numbered from bottom to top.

- LED 5: Heat issue
- LED 4: not applicable
- LED 3: Speed sensor issue
- LED 2: Motor issues
- LED 1: battery issues

For LED 5, heat issue: The bike needs some time to cool down. Restart the bike after a few minutes. Release stress on motor during high temperatures.

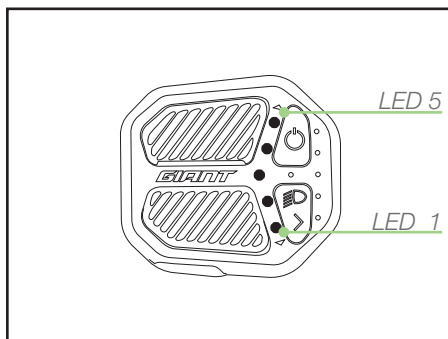

## 6 FREQUENTLY ASKED QUESTIONS

### 6.1 RIDECONTROL - DISPLAY

My Charge display can be rotated over the handlebar. Giant should have tightened this better.

- The Charge display should not be overtightened. It should be able to rotate a little in case of rude contact.

Can I upgrade my Charge display with an EVO display?

- Giant E-parts are mostly interchangeable. Swapping a Charge display for an EVO version is possible.

There is an error code on my screen. What should I do now?

- The error code shows something irregular has happened. It is best to contact your dealer shortly. It will not harm your bike if you continue using it.

An error code was displayed on my display, but now it is gone. What should I do?

- An error has occurred. The error is not persistent. There is no need to contact your dealer immediately and the error can be checked during your next routine service check.

When I change settings on my EVO display, it seems the new digits stacks up to the old ones. Can you explain what is going on?

- The EVO display is a 'liquid crystal display', using liquid for displaying data. When it's getting colder, it takes longer for the digits to fade out. The display is not broken. New settings like adjusting the assistance level are active instantly.

### 6.2 ENERGYPAK

How do I know how much charge my EnergyPak has when it is not connected to the bike?

- By pushing the power button on the EnergyPak, LEDs will light up, indicating the remaining capacity.

There are EnergyPak with 300, 400 and 500Wh. Why is the housing not consequently bigger?

- For different capacities, Giant uses cells with different densities. This way, housing can be the same and fit a variety of bikes.

Can I retrofit a bigger capacity Giant EnergyPak in my bike?

- Yes, Giant EnergyPak are interchangeable.

How come the charge times are not even with the capacity?

- Charging an EnergyPak is not done in a straight line. Especially the last part takes a lot of time.

Should I always empty my EnergyPak completely before recharging?

- There is no need to do complete discharge every time. Complete discharge every 3 months is appreciated for refreshing EnergyPak management.

What happens if my EnergyPak gets empty while riding?

- Obviously, assistance will stop. At 3%, assistance will be less to improve range. At 1%, assistance will stop completely. Lights will still function for about 2 or 3 hours. Your bike can be ridden without assistance.





## 6.3 SYNCDRIVE MOTOR

If I simply rotate my pedals, I hardly get any assistance. How come?

- Giant's SyncDrive central motor has a torque sensor. The motor assists accordingly the applied force. More basic systems can use rotation sensor only.

I can feel sideways play on my cranks. Is this normal?

- That is ok. Giant SyncDrive Central motor by Yamaha has been designed with a sideways play in the bottom bracket axle with a maximum of 1 millimeter. This has been done for better durability under all conditions.

How come competition motors make a different sound?

- Giant uses different internal structure than some competitors. As a consequence, we have a slightly higher frequency and better torque value.

## 6.4 MISCELLANEOUS

What is the QR code on my bike for?

- The QR code can be used to register your bicycle on an anti-theft website.

What is the best way to clean my bike?

- The E-parts are best cleaned with a dry cloth. The rest of the bike should be treated as any other bike.

Can I mount wired lighting system on my bike?

- Yes, wiring and buttons are prepared for this. Be sure to use correct type of lighting (6V for example).

My partner rides the same bike as I do. My range is much bigger. How come?

- Range is depending on a lot of influences (tire pressure, engaged own power, gear). One of them may cause this difference.

# 7 LEGAL DOCUMENTATION

## 7.1 WARRANTY

Giant warrants for the original owner only the frame, rigid fork, or original component parts of each new Giant brand bicycle to be free from defects in material and workmanship for the following specified periods:

Warranty of one year for electronical equipments such as:

- RideControl display & buttons
- SyncDrive motor
- EnergyPak battery; Per year, a loss of no more than 20% of its original nominal capacity at a maximum of 300 charges.
- Wiring

The maximum permissible total weight (bike, rider and luggage) for our E-bikes is 156Kg (344lbs).

For all other parts and components we refer to Giant's general user manual that been delivered with this E-bike as well. That user manual is leading in case of any issues. Text below and chapter 7.2 is just for reference.

### REQUIRED ASSEMBLY WHEN PURCHASED.

This warranty applies only to bicycles and framesets purchased new from an Authorized Giant Dealer and assembled by that dealer at the time of purchase.

### LIMITED REMEDY

Unless otherwise provided, the sole remedy under the above warranty, or any implied warranty, is limited to the replacement of defective parts with those of equal or greater value at the sole discretion of Giant. This warranty extends from the date of purchase, applies only to the original owner, and is not transferable. In no event shall Giant be responsible for any direct, incidental or consequential damages, including, without limitation, damages for personal injury, property damage, or economic losses, whether based on contract, warranty, negligence, product liability, or any other theory.

Giant makes no other warranties, express or implied. All implied warranties, including the warranties of merchantability and fitness for a particular purpose are limited in duration to that of the express warranties stated above.

Any claim against this warranty must be made through an Authorized Giant Dealer or distributor. The purchase receipt or other proof of the date of purchase is required before a warranty claim may be processed.

Claims made outside the country of purchase may be subject to fees and additional restrictions. Warranty duration and detail may differ by frame type and/or by country. This warranty gives you specific legal rights, and you may also have other rights which may vary from place to place. This warranty does not affect your statutory rights.



## 7.2 EXCLUSIONS

Normal wear and tear on parts such as tires, chains, brakes, cables and gearwheels in situations where there are no assembly or material defects.

- Bicycles serviced by other than an Authorized Giant dealer.
- Modifications from the original condition.
- Use of the bicycle for abnormal, competition and/or commercial activities or for purposes other than those for which the bicycle was designed.
- Damage caused by failing to follow the owner's manual.
- Paint finish and decal damage resulting from taking part in competitions, jumping, downhill and/ or training for such activities or events or as a result of exposing the bike to, or riding the bike in, severe conditions or climates.
- Labour charges for part replacement or changeover.

Except as is provided by this warranty and subject to all additional warranties Giant and its employees and agents shall not be liable for any loss or damage whatsoever (including incidental and consequential loss or damage caused by negligence or default) arising from or concerning any Giant bicycle.

## 7.3 CONFORMITY

**CE** Hybrid power bicycles with a maximum support speed of 45km/h fulfil the requirements of EU Directive 168/2013/EC for L1e-B category vehicles.

Hybrid power bicycles with a maximum support speed of 25km/h fulfil the requirements of EU Machinery Directive 2006/42/EC.

These bicycles also comply with the following non-harmonized standards:

- Bicycle standard: ISO 4210-2
- Electric bicycles: EN 15194

The declaration of conformity for your specific Giant E-bike can be found as an inlay in this user manual.

### Disclaimer

We strongly advise you not to remove or replace any original equipment or modify your cycle in any way that may change its design and/or operation. Such changes could seriously impair your cycle's handling, stability and other aspects of the cycle, making it unsafe to ride. Removing or modifying parts or using non-original equipment as replacements can also render your bike not in compliance with the applicable laws and regulations. To ensure safety, quality and reliability, use only original parts or Giant authorized replacements for repair and replacement.

## 7.4 FCC

This device complies with part 15 of the FCC Rules. Operation is subject to the following two conditions:

- (1) This device may not cause harmful interference, and
- (2) this device must accept any interference received, including interference that may cause undesired operation.

Please note that changes or modifications not expressly approved by the party responsible for compliance could void the user's authority to operate the equipment.

Note: This equipment has been tested and found to comply with the limits for a Class B digital device, pursuant to part 15 of the FCC Rules. These limits are designed to provide reasonable protection against harmful interference in a residential installation. This equipment generates, uses and can radiate radio frequency energy and, if not installed and used in accordance with the instructions, may cause harmful interference to radio communications. However, there is no guarantee that interference will not occur in a particular installation. If this equipment does cause harmful interference to radio or television reception, which can be determined by turning the equipment off and on, the user is encouraged to try to correct the interference by one or more of the following measures:

- Reorient or relocate the receiving antenna.
- Increase the separation between the equipment and receiver.
- Connect the equipment into an outlet on a circuit different from that to which the receiver is connected.
- Consult the dealer or an experienced radio/TV technician for help.

This equipment complies with radio frequency exposure limits set forth by the FCC for an uncontrolled environment.

This equipment should be installed and operated with a minimum distance of 5mm between the device and the user or bystanders.

This device must not be co-located or operating in conjunction with any other antenna or transmitter.

## 7.5 IC

This device complies with Industry Canada's licence-exempt RSSs. Operation is subject to the following two conditions:

- (1) This device may not cause interference; and
- (2) This device must accept any interference, including interference that may cause undesired operation of the device.

Le présent appareil est conforme aux CNR d'Industrie Canada applicables aux appareils radio exempts de licence. L'exploitation est autorisée aux deux conditions suivantes:

- (1) l'appareil ne doit pas produire de brouillage;
- (2) l'utilisateur de l'appareil doit accepter tout brouillage radioélectrique subi, même si le brouillage est susceptible d'en compromettre le fonctionnement.

This equipment complies with radio frequency exposure limits set forth by the Innovation, Science and Economic Development Canada for an uncontrolled environment.

This equipment should be installed and operated with a minimum distance of 5mm between the device and the user or bystanders.

This device must not be co-located or operating in conjunction with any other antenna or transmitter.

Cet équipement est conforme aux limites d'exposition aux radiofréquences définies par la Innovation, Sciences et Développement économique Canada pour un environnement non contrôlé.

Cet équipement doit être installé et utilisé avec un minimum de 5mm de distance entre le dispositif et l'utilisateur ou des tiers.

Ce dispositif ne doit pas être utilisé à proximité d'une autre antenne ou d'un autre émetteur.

