

INTRODUCTION

Congratulations on the purchase of a new Giant Crest 34 suspension fork. Building on our over 40 years of expertise in the science of bicycle and bicycle component manufacturing, Giant introduces the Crest 34 fork series, our all-new, fully tunable suspension fork that brings plush action and precise control to more riders everywhere, helping them ride more efficiently and safely in technical terrain.

IMPORTANT: PLEASE READ BEFORE RIDING

This user manual contains important safety, performance and service information. Please keep it for future reference. We strongly urge you to read the Crest 34 suspension fork owner's manual in its entirety before your first ride. If you have any questions about this manual or your Crest 34 fork, please contact a Giant authorized retailer.

WARNING

- Do not use the suspension fork for the following types of riding: Free ride, downhill or other types of extreme riding.
- The Crest 34 Fork is not intended for use on E-bikes.
- Ignoring Crest 34 fork safety instructions can cause serious injury or death.
- Do NOT use a high pressure washer to clean the suspension fork.
- Non-compliance with the user manual can cause product damage and will void your warranty.

CAUTION

- Please select the Giant Crest 34 fork which matches your bicycle's specification.
- Maximum riding weight for the Crest 34 fork is 136kg (299lbs). This includes rider + accessories. For safety, please do not exceed the specified weight limit.
- Modification of the product from its original condition is not covered by Giant limited warranty. Disassembly or modification of any type to the Crest 34 fork WILL VOID the warranty.
- Regularly maintain your Crest 34 fork through a Giant authorized retailer. Maintenance and replacement of components by a non-authorized retailer WILL VOID the warranty. All service and replacement parts must be Giant components only.
- Make sure to comply with setting, usage maintenance and service information instruction to ensure your riding safety. Ignoring Crest 34 fork safety instructions can cause serious injury or death.

SERVICE AND TECHNICAL SUPPORT

If you encounter difficulties or are uncertain about anything mentioned in this user manual, please contact a Giant authorized retailer.

For more information, please visit:
<https://www.giant-bicycles.com/global/manuals>

To find a Giant authorized retailer or to learn more about Giant Bicycles, please visit: www.giant-bicycles.com/global



CHECK YOUR BIKE BEFORE RIDING

- Check the correct functioning of the braking system. For more information on various common brake systems please visit:
 - Shimano: <https://si.shimano.com/#/>
 - SRAM: <https://www.servicearchive.sram.com/service>
 - TRP: <https://trpcycling.com/downloads/>
 - Tektro: <https://www.tekro.com/download.php?t=7>
 - If you are unsure of which brake system your bike is equipped with, please visit a Giant authorized retailer.
- Check the correct tire pressure for your tire type and riding experience.
 - If you are unsure of which tire your bike is equipped with, please visit a Giant authorized retailer.
- Check the correct tightness of thru axles. If you need more information, please visit:
 - Giant: <https://www.giant-bicycles.com/global/manuals>
 - If you encounter difficulties, please contact a Giant authorized retailer.
- Check the surface of the suspension fork for bending, deformation, cracking, etc.
 - Stop riding your bike immediately and contact a Giant authorized retailer if you encounter any issues.
- Check the suspension fork for leaks.
 - Stop riding your bike immediately and contact a Giant authorized retailer if you encounter any issues.
- Check the correct air pressure setting of the suspension fork.
 - If you encounter difficulties, please contact a Giant authorized retailer.
- Check the correct tightness of all bolts. For more information, please visit:
 - Giant: <https://www.giant-bicycles.com/global/manuals>

GIANT CREST INTRODUCTION

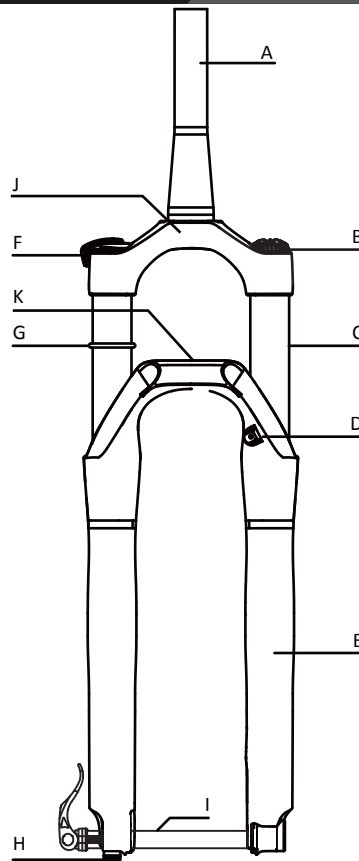

- F. Low speed compression cap
- G. O-ring
- H. Rebound adjustment knob
- I. Thru axle
- J. Crown
- K. Lower leg arch

- A. Tapered steerer tube
- B. Air spring cap
- C. 34mm stanchion
- D. Brake cable guide
- E. Lower leg

INSTALLATION INSTRUCTION

WARNING

- The suspension fork should be installed by a Giant authorized retailer in accordance with stated installation instructions. Improper installation will cause malfunction of your suspension fork and could cause serious injury or death.
- Bending, deforming and cracking of the surface of steerer tube can cause a break or malfunction which can cause serious injury or death.
- Modification of any type to the fork WILL VOID the warranty. Any modifications of steerer tube other than cutting to the appropriate length to fit your bicycle can cause a break or malfunction which can cause serious injury or death.
- The spacers of the steerer tube should be less than 30mm from bottom of stem to top of the head tube. More than 30mm of spacers can cause a break or malfunction which can cause serious injury or death.
- Do not use a length of steerer tube which is too short. The gap between the top edge of the steerer tube and the surface of the stem should be 2~5mm with the height of the top edge of the steerer tube being higher than the first bolt of stem. An insufficient length of steerer tube can cause a break or malfunction which can cause serious injury or death.
- Refer to the stem manufacturer's user manuals for stem installation. Improper installation can cause a break or malfunction which can cause serious injury or death.

GIANT CREST 34 FORK INSTALLATION

1. Select the correct Giant Crest 34 fork which best fits your bicycle's specification and remove the original fork.
2. Remove the headset crown race from the original suspension fork.
3. Refer to the headset manufacturer's user manuals and headset crown race setting tool to install the headset crown race on the Giant Crest 34 fork.
4. Measure the length of steerer tube of the original suspension fork and replicate the measurement on the steerer tube of the Giant Crest 34 fork.
5. Cut the length of steerer tube if it is necessary by using a cutting guide.
6. Use the star nut setting tool to insert the star nut at a depth below 12~16mm from the end the steerer tube.
7. Check that the headset is installed correctly on the bicycle frame.
8. Fit the Giant Crest 34 fork into the bicycle's frame.
9. Install a spacer or spacers on the steerer tube. Please note the height of each individual spacer should be less than 30mm.
10. Install the stem on the steerer tube. Please refer the stem manufacturer's user manual to install the stem properly.
11. Tighten the top cap to the torque value recommended in the headset manufacturer's user manual.
12. Tighten the bolts of stem to the torque value recommended in the stem manufacturer's user manual.

If you have difficulties or are uncertain about this procedure, contact a Giant authorized retailer.

REMOTE CONTROL INSTALLATION

Tighten the bolts of remote control to the recommended torque value of 2~2.5Nm, as shown in Figure 1.

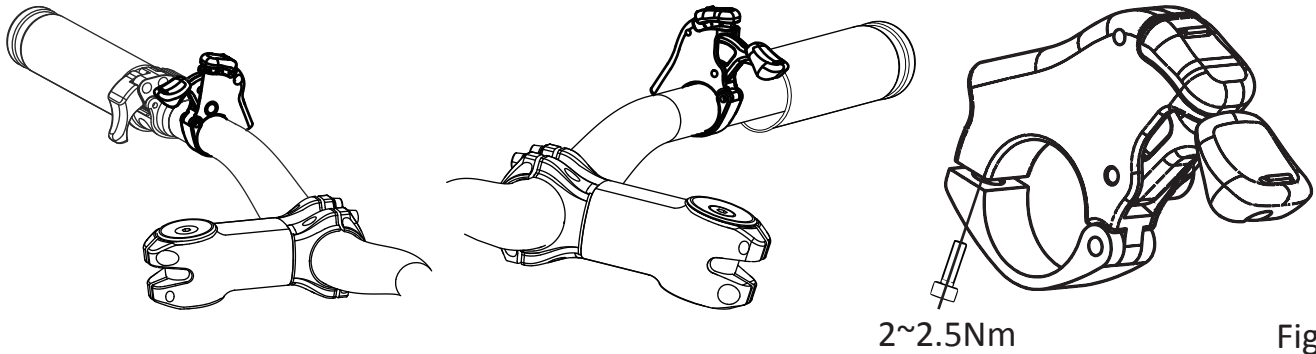

Figure 1

DISC BRAKE INSTALLATION

1. Refer to the disc brake manufacturer's user manual to install the brake caliper to the fork leg.
2. Fix the disc brake hose onto the Giant Crest 34 fork using the supplied bracket and tighten the bolt to the recommended torque value, as show in Figure 2.



Figure 2

⚠ WARNING

- It is strongly recommended that you have the disc brake system installed and/or checked by a Giant authorized retailer in accordance with the manufacturer's user manual.
- Before riding, check disc brake system installation again. Improper installation can cause malfunction of the system and lead to serious injury or death.

⚠ CAUTION

- The range of compatible rotor sizes of the disc brake system on the Crest 34 fork is from 160mm to 180mm. Refer to the disc brake manufacturer's user manual for the installation procedure, install the correct adapter and tighten the bolts to the recommended torque value.
- Follow all directions indicated in the disc brake manufacturer's user manual for correct installation of the disc brake system.

WHEEL INSTALLATION

⚠ WARNING

Giant Crest 34 models are equipped with a 15mm thru-axle system featuring an indexed nut for proper closure adjustment. Please consult a Giant authorized retailer to make sure you have a complete understanding of how to correctly install the thru-axle before riding. Improper installation can cause malfunction of the wheel and lead to serious injury or death.

Thru axle system

1. Install the front wheel onto the Giant Crest 34 suspension fork. Align the hub of the front wheel with dropouts of the fork, making sure the rotor of the disc brake system is correctly aligned between the brake pads of the brake caliper. If the hub and/ or rotor do not align, do not force the wheel, remove it and start the process again. Refer to the disc brake manufacturer's user manual for proper set up and alignment of the disc brake.
2. With the lever of the thru-axle in the open position, insert the thru-axle through the fork drop out and the hub from the drive side.
3. Tighten the thru-axle clockwise until there is a small gap between the lever head and fork dropout so that it is in a horizontal position pointing forwards. The lever should close smoothly and firmly until it is pointing away from the front of the bike. You should not have to force it closed. Tension is sufficient if the lever leaves a slight imprint on your hand. (Figure 3).

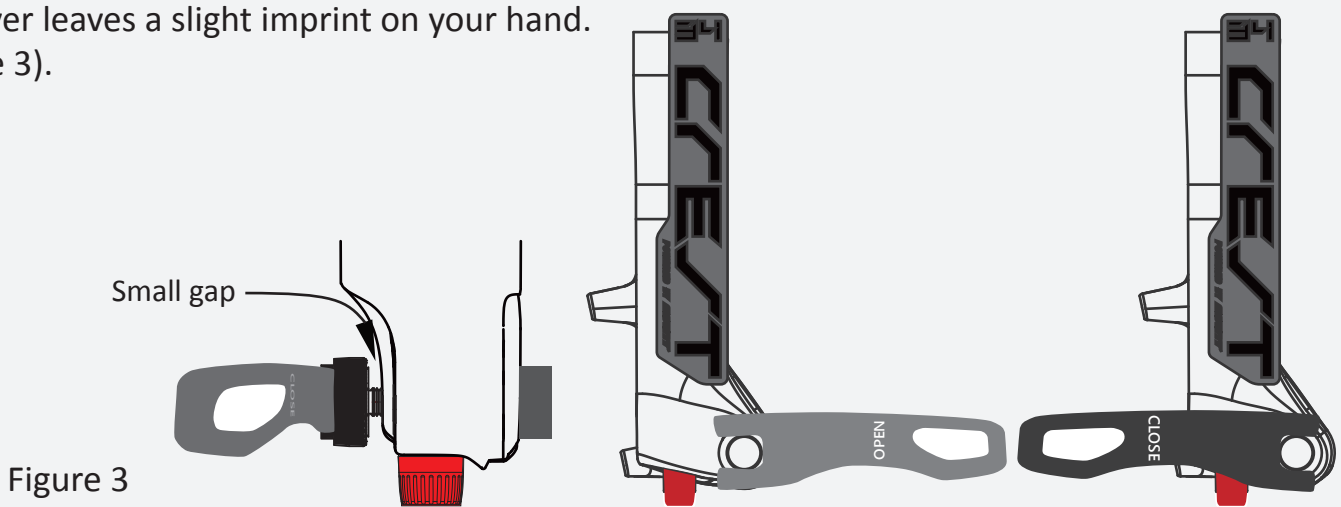

4. If the lever is too tight to close, do not force it, remove the thru-axle and adjust the indexed nut on the non-drive side of the fork by one increment in a counter-clockwise direction. Repeat as necessary until the lever closes smoothly and firmly.

5. If the lever is too loose and does not close firmly, remove the thru-axle and adjust the indexed nut on the non-drive side of the fork in a clockwise direction (Figure 4). Repeat as necessary until the lever closes smoothly and firmly.

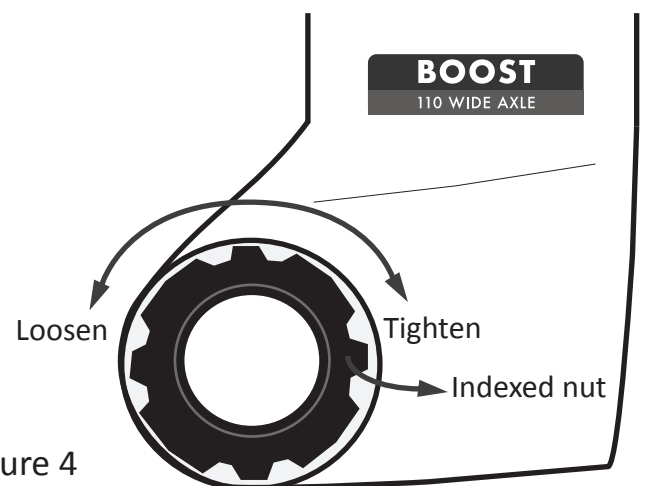

Figure 4

If you are unsure about the tightness or the position of the thru-axle after installation, please consult a Giant authorized retailer.

TIRE & WHEEL SIZE COMPATIBILITY

The Giant Crest 34 suspension fork is available for 27.5 inch and 29 inch wheel dimensions. The Crest 34 27.5 fork fits up to a 27.5 x 2.6 standard tire and the Crest 34 29 fork fits up to a 29 x 2.4 standard tire. Any tire size must be checked with fork fully compressed and have a minimum of 6.0 mm tire to crown/or lower leg arch clearance. Please check the original specification of your bike and refer the manufacturer's user manuals for tire installation recommendations and instructions.

⚠ WARNING

The tire clearance value between the top of the tire and bottom of the arch or crown on the lower leg of the fork must be at least 6mm with fork fully compressed, as shown Figure 5. Insufficient tire clearance can cause malfunction of your wheel and result in serious injury or death.

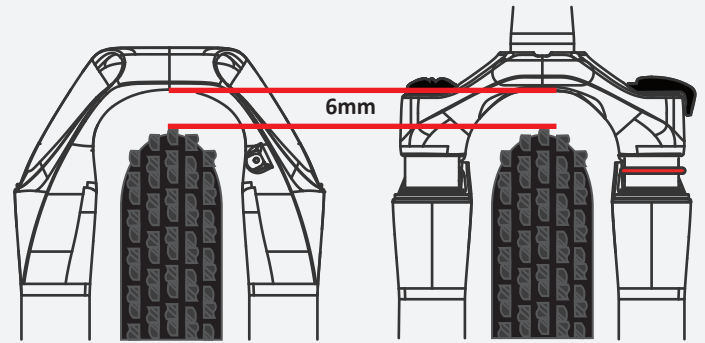

Figure 5

SETTING YOUR GIANT CREST 34 SUSPENSION FORK

Ramp Adjustable Twin Air Spring

The Crest 34 fork features a lightweight air spring with a self-equalized negative air chamber for increased sensitivity. With tight inner diameter tolerances and precise piston sizing, the air springs give a progressive spring rate, and provide more support when pushing harder. Riders can also fine-tune the positive spring using volume spacers to adapt to their riding style and rider weight.

SAG SETTING

Setting appropriate the sag value of your Giant Crest 34 suspension fork to achieve optimal suspension performance:

1. Before setting the sag value, turn the rebound damper knob counterclockwise (to the fastest setting) until it stops and move the low speed compression knob counterclockwise to open position.
2. Check your weight with the suggested air spring pressure value and use a shock pump to add air until you reach to the correct suggested pressure.
3. Move the O-ring down the stanchion to the seal of the fork lower.
4. Using a wall, fence, tree or an assistant for support, get on your bike wearing full riding kit and assume a natural riding position with both feet on the pedals and hands on the handlebars.
5. Gently get off your bike and measure the distance from the seal of the fork lower to the O-ring to determine the sag value.
6. Adjust air pressure and repeat steps 1-5 above until you reach recommended sag.

IMPORTANT: If the recommended air pressure for rider weight is less than 100psi, add air to the chamber until you reach 100psi and then use the shock pump to gradually release air to the desired pressure.

SUGGESTED SAG VALUE

FORK TRAVEL (mm)	SAG (%)	SAG (mm)
100	20	20mm
120	20	24mm

AIR SPRING PRESSURE SETTING

	120MM TRAVEL	100MM TRAVEL
RIDING WEIGHT kg (lbs)	AIR PRESSURE (psi)	AIR PRESSURE (psi)
54-59 (120-130)	56	61
59-64 (130-140)	63	69
64-68 (140-150)	70	76
68-73 (150-160)	76	82
73-77 (160-170)	83	89
77-82 (170-180)	89	98
82-86 (180-190)	96	103
86-91 (190-200)	102	110
91-95 (200-210)	109	117
95-100 (210-220)	116	124
100-104 (220-230)	123	131
104-109 (230-240)	130	138
>109 (>240)	140	140
MAX RIDING WEIGHT LIMIT	136kg (299lbs)	136kg (299lbs)
MAX. AIR PRESSURE	140	140

AIR SPRING VOLUME TOKEN SETTINGS

	120MM TRAVEL	100MM TRAVEL
FACTORY INSTALLED TOKENS	1	3
MAX. NUMBER OF TOKENS	4	5

**WARNING**

Do NOT exceed the maximum number of air tokens and / or maximum air pressure for the fork.

GIANT TUNING DAMPER

Tuned with input from our experienced suspension developers, the fully adjustable damper can be continuously refined for increased control and to allow a wide range of riders to easily match their suspension with the terrain and their riding style.

LOW SPEED COMPRESSION ADJUSTMENT

The multi-function adjustable compression circuit has three modes: Open mode, 3x Trail modes and Lock-Out mode. Open mode allows full compression for descending on more technical terrain while Trail and Lock-Out modes give progressively firmer damping for riding rolling terrain or for climbing (Figure 6).

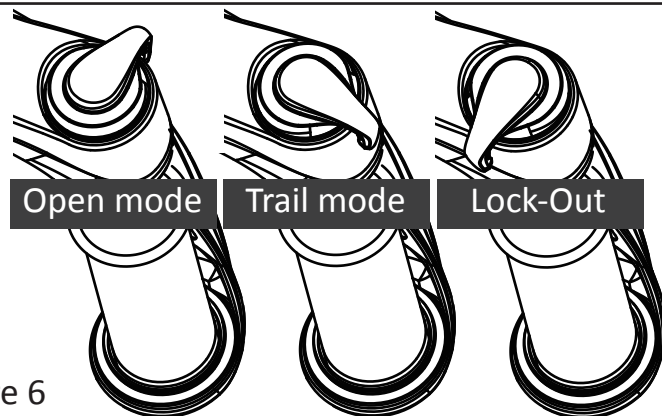
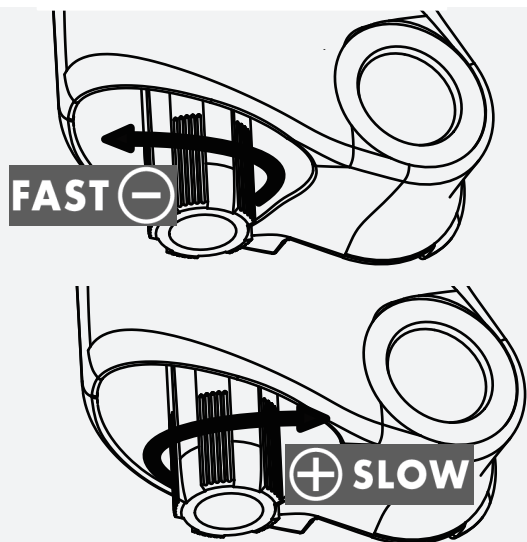

Figure 6



REBOUND ADJUSTMENT

Rebound controls the extension speed of the Giant Crest 34 suspension fork when the fork compresses during your ride. Adjust the rebound speed of your Giant Crest 34 fork to fit your preferred riding style.

The indexed points are from slowest "0 clicks" position (turn rebound damper knob completely clockwise) to fastest "24 clicks" position (turn rebound damper knob completely counterclockwise).

Figure 7

REMOTE CONTROL OPERATION

Certain Giant Crest 34 models are equipped with a handlebar mounted two position (open/lock-out) remote control.

When the lever is clicked down, the fork is locked out. When it is clicked up, by pressing the release button, the fork is in open mode (Figure 8).

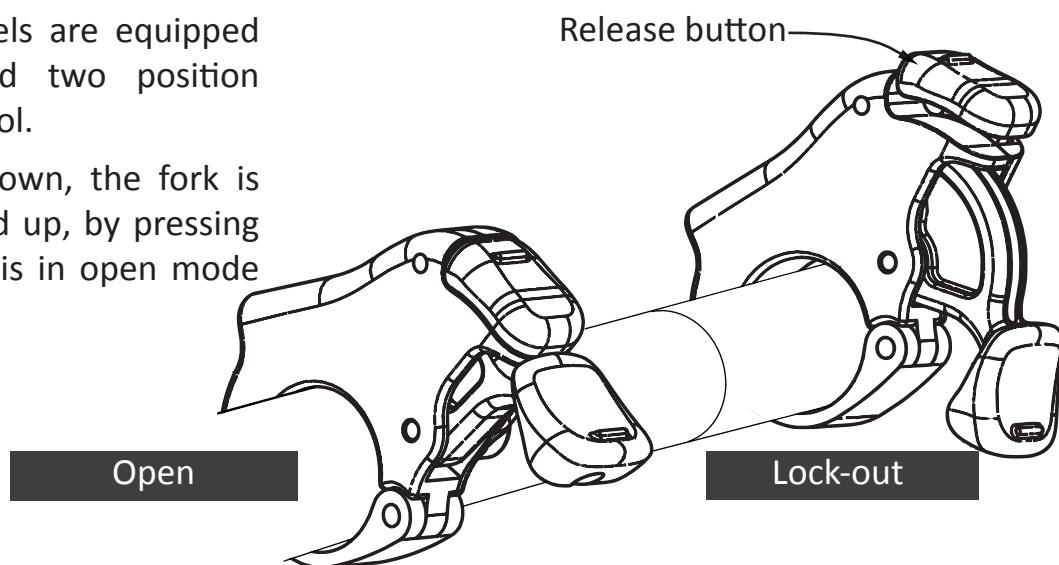

Figure 8

CREST FORK SERVICE & MAINTENANCE

Service interval	Action
Before riding	Check your fork, bike and all components for wear and damage
After each ride	Clean fork stanchions and wiper seals
After 50 hours of riding	Fork lower leg service
After 200 hours of riding or 1 year	Air spring and Damper service

 **WARNING**

- Do NOT use high pressure washers to clean the Crest 34 fork as you may cause damage to the wiper seals.
 - Do not disassemble or modify the Crest 34 fork. This WILL VOID your warranty.
 - All fork service must be performed by a Giant authorized retailer or service center.
 - The Giant Crest 34 fork must be stored and operated at a temperature between -30°C ~ 80°C.
- If you encounter any issues with your Crest 34 fork at any time, please contact a Giant authorized retailer immediately.

GIANT LIMITED WARRANTY

Giant warrants its Crest 34 suspension fork for a period of two (2) years from the date of purchase.

This warranty applies only to the original owner, and when the fork is purchased new from a Giant authorized retailer and assembled by that retailer at the time of purchase.

LIMITED REMEDY

Unless otherwise provided, the sole remedy under the above warranty, or any implied warranty, is limited to the replacement of defective parts with those of equal or greater value at the sole discretion of Giant. This warranty extends from the date of purchase, applies only to the original owner, and is not transferable. In no event shall Giant be responsible for any direct, incidental or consequential damages, including, without limitation, damages for personal injury, property damage, or economic losses, whether based on contract, warranty, negligence, product liability, or any other theory.

EXCLUSIONS

The above warranty, or any implied warranty, does not cover:

- Normal wear and tear on parts in situations where there are no assembly or material defects.
- Consumable components including bolts, nuts, caps, cartridge, rebound knob, O/X-ring, thru-axle, quick release, and piston set.
- Products serviced by anyone other than a Giant authorized retailer.
- Modifications of the product from its original condition.
- Use of this product in abnormal or extreme riding conditions, competition, commercial activities and / or for purposes other than those for which this product was designed.
- Damage caused by failing to follow the User's Manual.
- Paint, finish and decal damage resulting from normal wear and tear or from taking part in competitions, jumping, downhill and/or training for such activities or events or as a result of exposing the product to, or operating the product in, severe conditions or climates.
- Labor charges for part replacement or changeover.

Except as is provided by this warranty and subject to all additional warranties, Giant and its employees and agents shall not be liable for any loss or damage whatsoever (including incidental and consequential loss or damage caused by negligence or default) arising from or concerning any Giant product.

Giant makes no other warranties, express or implied. All implied warranties, including the warranties of merchantability and fitness for a particular purpose are limited in duration to that of the express warranties stated above.

Any claim against this warranty must be made through a Giant authorized retailer or distributor. The purchase receipt or other proof of the date of purchase is required before a warranty claim may be processed.

Claims made outside the country of purchase may be subject to fees and additional restrictions. Warranty duration and details may differ by country. This warranty gives you specific legal rights, and you may also have other rights which may vary from place to place. **THIS WARRANTY DOES NOT AFFECT YOUR STATUTORY RIGHTS.**